

ATR 06 // liertrommels



- Liertrommels en band trommels voor elektrische aandrijvingen en handmatige aandrijvingen met uitvoeras We 06 (ø 26 mm, met haakse boring), met schroef M 10 ter bevestiging op de as.
- Kabeldiameter $D \varnothing = 4,0-6,0$ mm ($F = \text{max. } 5000$ N).
- ATR 06.5403 zowel links alsook rechts op de aandrijving te gebruiken.
- Bandbreedte $B = 50$ mm ($F = \text{max. } 5000$ N).
- Verdere liertrommels op aanvraag.

Opmerking:

- Kabel niet bij levering inbegrepen.
- Vermelding H zonder twee veiligheidswikkelingen.

Versie	Art.nr.	DR [mm]	DIN 3069 D ø [mm]	H1 [m]	H2 [m]	Wikkelwijze	m [kg]
ATR 06.6001	81006.6001.01	60	5-6	2,3	5,7	glad	2,1
ATR 06.5401	81006.5401.01	54	4-5	2,6	6,2	glad	0,7
ATR 06.5410	81006.5401.10	54	-	-	-	glad	0,7
ATR 06.9201	81006.9201.01	120	6	3,5	-	glad	2,5
ATR 06.6002	81006.6002.01	61	5	2,4	6,0	met groeven/links	2,3
ATR 06.6003	81006.6003.01	61	5	2,4	6,0	met groeven/rechts	2,3
ATR 06.5403	81006.5403.02	54	5	2,8	6,9	met groeven/links	0,9

Versie	Art.nr.	B [mm]	L [mm]	m [kg]
GBA 20.5010	81520.5010.0110	50	1000	0,2
GBA 20.5025	81520.5010.0125	50	2500	0,3

ATR 06.6001

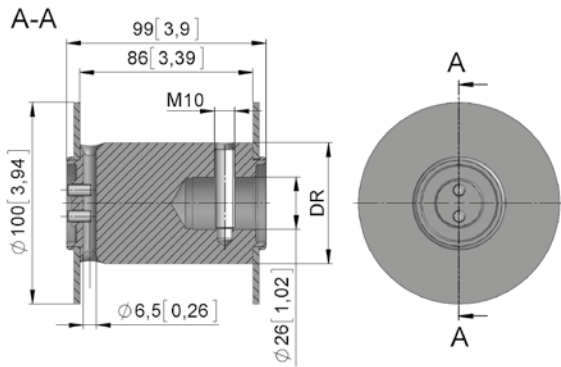

ATR 06.5401

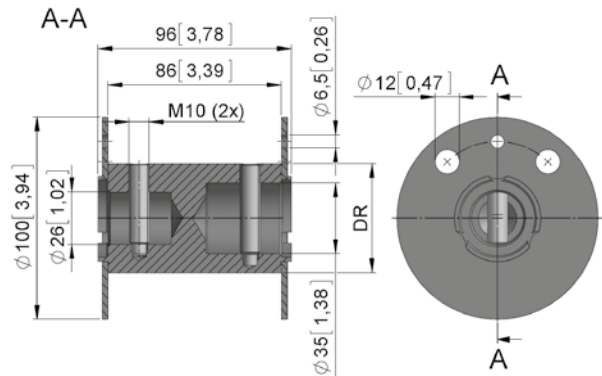

ATR 06.9201

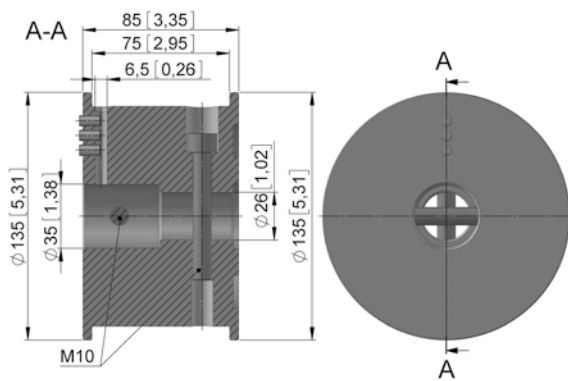

ATR 06.5410

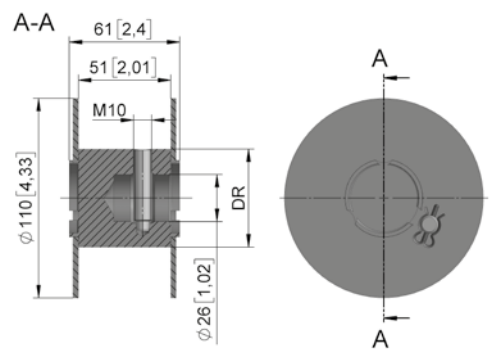

ATR 06.6002 // ATR 06.6003

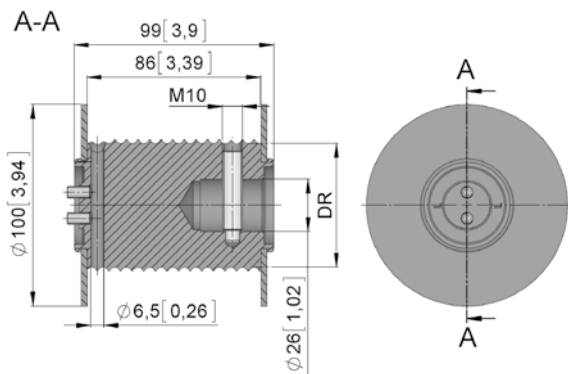

ATR 06.5403

