

# → SYSTEM-KIT 90000.0002.7558



No transport of persons and goods in dynamic operation

Lifting load max.	23 KN
Stroke length max. (*)	1.300 mm
Lifting speed appr.	430 mm/min.
Engine group (DIN 15020)	1Cm at load collective L3
Useful life (**)	400 h at T1 ( $\leq 0,25$ h daily)
Operating standard	DIN EN 1570-1 / DIN EN 280 + MRL (CE)
Ambient temperature	-5°C to +50°C / Optional down to -25°C
/ Control box	-25°C up to +40°C
Degree of protection	IP 55
Performance Level	(PL)c
Supply voltage	230V 1~ / 50Hz / 1,1KW
Shaft speed	120 U/min.
(Gearbox output)	

(\*) Unfavorable load distribution  
max. 50% of the lifting load each rack

(\*\*) Duration  $t_i > 5$ min, then  $t_p > 30$  min

CE conformity / risk analysis of  
the entire system is carried out  
by the customer

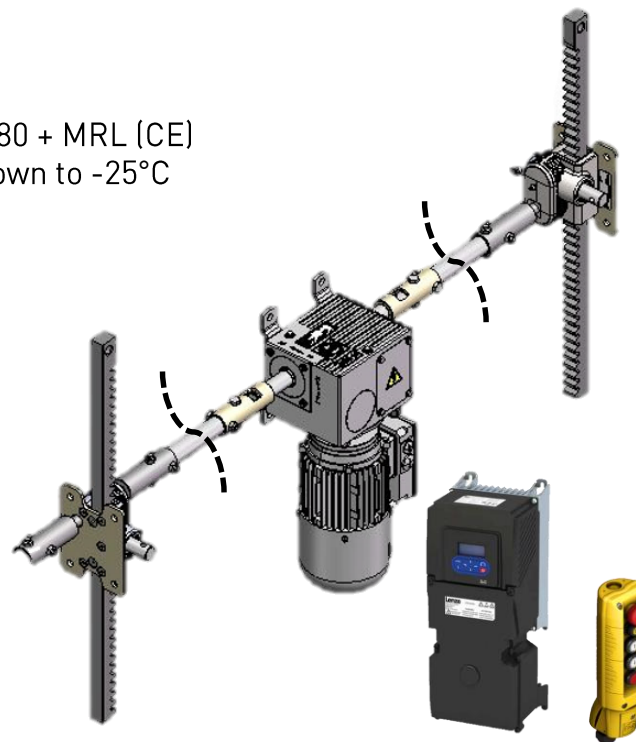

No transport of persons  
In dynamic mode

 = Erweiterung  
Connecting shaft  
provided by the customer